



Quick Installation Guide

FriendlyNET 696 10/100 PCI Fast Ethernet Adapter



Introduction

Thank you for purchasing Asanté's AsantéFast 696 10/100 Mbps PCI Fast Ethernet Adapter. This adapter is designed to be the most powerful way to start or expand your small business or home office network.

- Compatible with all industry-standard 10BaseT, and 100BaseTX network switches, hubs and routers.
- Easy to install – simply install the card into a vacant PCI slot, connect the cables, run the Installer or Wizard, and start using your new adapter!
- Easily monitor your network access with LED indicators.
- Free telephone technical support when used with Windows 95, 98, NT, NDIS driver for LAN Manger, Packet Driver for TCP/IP software, and MAC OS 8.6 or higher.

Packing List

Your package contains the following items:

- (1) 696 10/100 PCI Fast Ethernet Adapter
- Category 5 Ethernet Cable
- Quick Installation Guide (this document)
- CD-ROM with applications drivers/manual

System Requirements

Mac Requirements (Minimum):

Macintosh with PCI slot
Mac OS 8.6 or higher.
RJ-45 Category 5 cable for 10BaseT and 100BaseTX

PC Requirements (Minimum):

PC with 32-bit PCI Bus
Microsoft Windows 95/98/NT4
RJ-45 Category 5 cable for 10BaseT and 100BaseTX

Installation

Here's how to install this adapter:

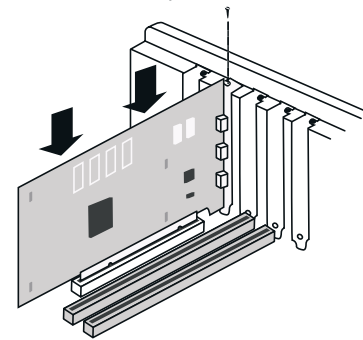

Hardware Installation

1. Turn off the power to the computer.
2. Insert the 10/100 PCI card into any available PCI slot. Connect the 100BaseTX or 10BaseT network Ethernet cable (Category 5 or better) from the hub, switch or router (purchased separately) to the RJ45 port of the adapter.
3. Turn on the power to your computer and allow the computer to start up to the desktop.

Software Installation

1. Insert the provided CD-ROM into your CD-ROM drive.
2. Installing the drivers from the CD-ROM:
 - a. **Windows** - follow the Hardware Installation Wizard and locate the driver on the CD-ROM.
 - b. **Macintosh** - locate the Installer in the Macintosh folder on the CD-ROM and follow the on-screen instructions.

In a few moments, you will see the status of your network with these LED indicators:

- A. Activity** – Green LED flashes during network activity.
- B. Link** – Green LED on if connection speed is at 100 Mbps, Amber LED on if connection speed is at 10 Mbps.

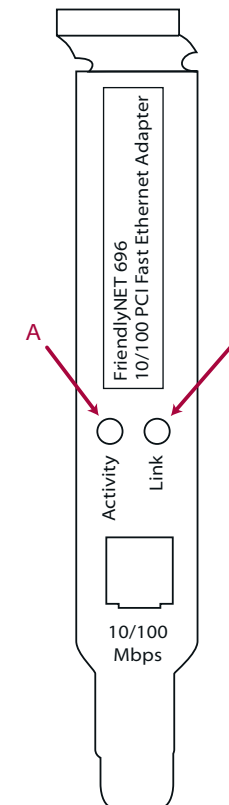

Visit Asanté at www.asante.com

Main Corporate Telephone Numbers
800-662-9686 (Home/Office Solutions)
800-303-9121 (Enterprise Solutions)
408-435-8388

Technical Support
801-566-8991 (Worldwide)

Technical Support Fax
801-566-3787



Copyright © 2000 Asanté Technologies, Inc. Asanté, the Asanté logo and FriendlyNET are trademarks of Asanté Technologies. All other brand names and products are trademarks or registered trademarks of their respective holders. All features and specifications are subject to change without prior notice. 06-00610-00 Rev. A, 05/01

Product Specifications

Connector: Fast Ethernet (100BaseTX and 10BaseT) RJ-45 connector

Drivers: Windows 95, 98, 2000, Me, and NT 4.0
See the Asanté website for the latest drivers

Status Indicators: 10/100 Mbps Link Activity

Bus Interface: 32-bit PCI Rev.2.1, Rev.2.2

Environmental Range

Operating Temperature: 0° C to 55° C
32° F to 131° F

Storage Temperature: -20° C to 70° C
-4° F to 158° F

Operating Humidity: 10 to 90%

Operating Storage: 5 to 90%

Standards Compliance

Network: IEEE 802.3 10BaseT Ethernet
IEEE 802.3u 100BaseTxFast Ethernet
ANSI/IEEE 802.3 NWay Auto-negotiation
IEEE 802.3X Full-duplex flow control

Performance: **Ethernet:** 10 Mbps (Half-duplex), 20Mbps (Full-duplex)
Fast Ethernet: 100 Mbps (Half-duplex), 200Mbps (Full-duplex)

Emissions: FCC Class B, CE

Product Registration

To register your Asanté product, please visit:
<http://www.asante.com/support/registration.html>

Troubleshooting Tips

In the unlikely event your network is not operating properly, follow the troubleshooting tips below.

- Check your adapter card. Is there a green network Link on the 10/100 LED? If not, try connecting a "known good" network cable between your switch and the adapter. You should see a Link LED on your switch and your network adapter. The maximum distance from any node (computer, printer, hub, switch, etc.) is 328 feet or 100 meters. Be sure your cable is not coiled, twisted or damaged. When connecting the switch to a computer, be sure your Category 5 UTP cable is wired for straight-through. Note that pins 3 and 6 must use the same twisted pair; these are typically orange/white orange or green/white green.
- Check your cable type. 10BaseT may use Category 3 (or better) cables. 100BaseTX may use Category 5 (or better).
- Check your uplink switch. When connecting to another hub or switch, set the switch to uplink on only one hub/switch and use a standard, straight-through network cable. This switch may be connected to another 10/100 Mbps switch or hub, but it will only run at 10 Mbps.
- Check your computer's software. Check your operating system manual for instructions on configuring your network for file and print sharing.

Need more help?

Consult the Asanté website (www.asante.com) for additional troubleshooting tips and frequently asked questions (FAQ). You may also contact Asanté Technical Support during standard business hours (7am to 6pm MST, Monday-Friday).

Email: support@asante.com

Phone: 801-566-8991

FAX: 801-566-3787

FCC Compliance Statement

This hardware device complies with Part 15 of the FCC Rules. Operation is subject to the following two conditions: 1) this device may not cause harmful interference, and 2) this device must accept any interference received, including interference that may cause undesired operation. NOTE: This hardware device has been tested and found to comply with the limits of a Class B computing device, pursuant to Part 15 of the FCC rules. These limits are designed to provide reasonable protection against harmful interference in a residential installation. This equipment generates, uses and can radiate radio frequency energy and, if not installed and used in accordance with the instructions, may cause harmful interference to radio communications. If you suspect this equipment is causing interference, turn your unit on and off while your radio or TV is showing interference. If the interference disappears when you turn the unit off and reappears when you turn the unit on, something in the unit is causing interference. You can try to correct the interference by one or more of the following measures: 1) reorient or relocate the receiving antenna; 2) increase the separation between the equipment and the receiver; 3) connect the equipment to an outlet on a circuit different from that to which the receiver is connected; 4) 4) Ensure that all expansion slots (on the back or side of the computer) are covered. Also ensure that all metal retaining brackets are tightly attached to the computer; 5) consult the place of purchase or an experienced radio/ television technician for additional suggestions. Any changes or modifications not expressly approved by the party responsible for compliance could void the user's authority to operate the equipment.

Safety Advisory

1. Always turn off power to your computer before installing hardware.
2. Always practice ESD techniques when installing hardware.
3. Always use this product in a cool, dry, dust-free environment or danger of electrocution or fire may result.
4. Never insert anything other than the recommended cable into the RJ45 port or damage may result.

