



## Quick Installation Guide

### GigaNIX 1000TA/TPC Gigabit Ethernet Adapters



#### Introduction

Thank you for purchasing an Asanté FriendlyNET GigaNIX Gigabit Ethernet adapter. This adapter is designed to be the most powerful way to start or expand your small business or home office network.

- Compatible with all industry-standard 10BaseT, 100BaseTX and 1000T network switches, hubs and routers.
- Easy to install—simply install the card into a vacant PCI slot, connect the cables, run the Installer or Wizard, and start using your new adapter!
- Easily monitor your network access with LED indicators.
- Free telephone technical support when used with Mac OS, Linux, Windows 95/98/NT and Windows 2000 Professional/Server.

This product comes in two configurations:

- FriendlyNET Dual Platform Gigabit Ethernet Adapter (1000TA)
- FriendlyNET PC Only Gigabit Ethernet Adapter (1000TPC)

#### Packing List

Your package contains the following items:

- (1) FriendlyNET GigaNIX Gigabit Ethernet Adapter
- (1) Quick Installation Guide (this document)
- (1) GigaNIX 1000TA/TPC CD-ROM
- (1) GigaNIX Release Note

#### System Requirements

**Macintosh Minimum Requirements (1000TA Only):** Power Macintosh running 8.6 or better with 32MB RAM; **Minimum Recommended for Gigabit:** G3 with 64M of RAM running OS9 or better.

**PC Requirements: (1000TA/TPC):** Minimum: Pentium 133 with 32MB RAM; **Minimum Recommended for Gigabit:** Pentium III with 64MB RAM or better. Windows 98 or later or Linux (Kernel 2.2.16 or greater recommended) required.

#### Installation

Here's how to install this adapter:

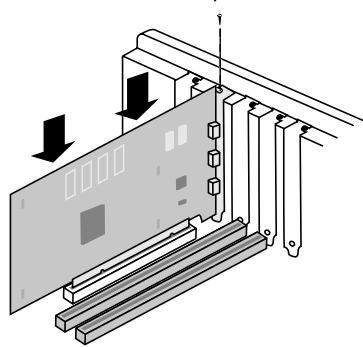

#### Hardware Installation

1. Turn off the power to the CPU.
2. Insert the 1000TA/TPC into any available PCI slot. Connect the 1000T, 100BaseTX or 10BaseT network cable (Category 3, 5 or 5"e") from the hub, switch or router (purchased separately) to the RJ45 port of your adapter.
3. Turn on the power to your computer and allow the computer to boot to the desktop.

#### Software Installation

1. Insert the CD into the CD-ROM.
2. Install the drivers:
  - a. **Windows** - follow the Hardware Wizard, locating the driver on the CD.
  - b. **Macintosh** - locate the Installer in the Macintosh folder on the CD and follow directions.
  - c. **Linux** - Compile and install the driver according to the instructions found in the Readme.linux file located in the Linux directory.
5. Reboot the computer.

In a few moments, you will see the status of your network with these LED indicators:

- A. **10Mbps** - Green LED is on when adapter is at 10Mbps. LED is on solid when there is a valid network link to the network adapter. It flashes during network activity (transmit or receive).
- B. **100 Mbps** - Green LED is on when adapter is at 100Mbps. LED is on solid when there is a valid network link to the network adapter. It flashes during network activity (transmit or receive).
- C. **1000Mbps** - Green LED is on when adapter is at 1000Mbps. LED is on solid when there is a valid network link to the network adapter. It flashes during network activity (transmit or receive).

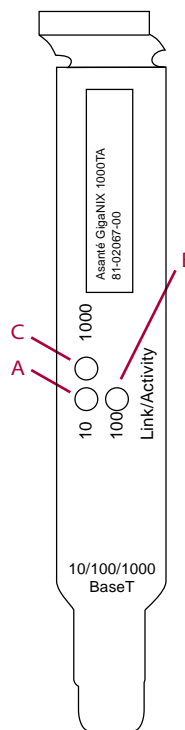

Please seal with tape, not staple or paperclip

Name \_\_\_\_\_

Title \_\_\_\_\_

Company \_\_\_\_\_

Address 1 \_\_\_\_\_

Address 2 \_\_\_\_\_

City \_\_\_\_\_

State \_\_\_\_\_

Zip/Postal \_\_\_\_\_

Country \_\_\_\_\_

Phone \_\_\_\_\_

Fax \_\_\_\_\_

Email \_\_\_\_\_

Date of Purchase \_\_\_\_\_

Asanté Part Number \_\_\_\_\_

Product Serial Number \_\_\_\_\_

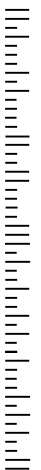

REGISTRATION CARDS  
 ASANTE TECHNOLOGIES, INC  
 821 FOX LANE  
 SAN JOSE CA 95131-9882

POSTAGE WILL BE PAID BY ADDRESSEE

**BUSINESS REPLY MAIL**  
 FIRST CLASS MAIL PERMIT NO. 4195 SAN JOSE CA

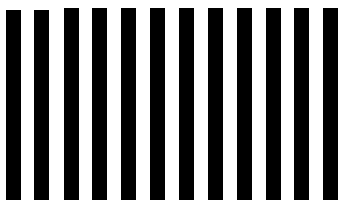

NO POSTAGE  
 NECESSARY  
 IF MAILED  
 IN THE  
 UNITED STATES

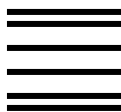

1) What is your organization's primary business?

- Advertising Agency/
- Public Relations
- CAD/CAM
- Graphic Arts Services
- Multimedia/Video
- Sales
- Finance
- College/University
- Higher Education
- K-12
- Manufacturing
- Medical/Dental
- Printers
- Prepress
- Publishing
- Transportation
- Corporate/In-plant, Non-commercial In-house Graphic Services
- Other: \_\_\_\_\_

2) My primary job function is (Check only one):

- Business Management (President, Owner, VP, etc.)
- Communications/Publishing Management
- Educational Management
- Management Information Systems (MIS)
- Graphic Arts/Design Management
- Production Management
- Department Supervision/Management

3) What is your influence on purchasing decisions?

- Authority to evaluate and purchase
- Evaluate and recommend

4) Have you previously purchased an Asanté product?

- Yes
  - No
- If yes, which product?
- Adapters
  - Hubs
  - Switches
  - Software
  - Other products

5) Where did you purchase this product?

- Reseller
- Direct from Asanté
- Distributor
- Mail Order
- Web
- Other: \_\_\_\_\_

6) Types of workstation operating systems:

- Mac OS
- Windows® 95/98
- Windows® NT/2000
- Linux
- UNIX
- MS DOS
- Solaris
- Other: \_\_\_\_\_

7) Number of nodes on your network:

- 2-10
- 10-50
- 50-100
- 100-500
- 500+

8) Type of network:

- LocalTalk
- Ethernet
- Fast Ethernet
- Gigabit Ethernet
- FDDI
- ATM

9) Type of network operating systems:

- Novell NetWare
- Microsoft NT/2000
- AppleTalk/MacLAN Connect
- AppleShare
- UNIX/Linux

10) Types of network management software:

- IntraSpecion
- AsantéView
- SunNet Manager
- IBM NetView
- Optivity
- HP OpenView
- Other: \_\_\_\_\_



Troubleshooting Tips

In the unlikely event your network is not operating properly, follow the troubleshooting tips below.

- Check your adapter card. Is there a green network Link LED on the 10, 100 or 1000 LED? If not, try connecting a "known good" network cable between your switch and the adapter. You should see a Link LED on your switch and your network adapter. The maximum distance from any node (computer, printer, hub, switch, etc.) is 328 feet or 100 meters. Be sure your cable is not coiled, twisted or damaged. When connecting the switch to a computer, be sure your Category 5 UTP cable is wired for straight-through; pins 1, 2, 3 and 6 should be matched pin-for-pin on both ends. Note that pins 3 and 6 must use the same twisted pair; these are typically orange/white orange or green/white green.

- Check your cable type. 10BaseT can use Category 3, 5 or 5"e" cable; 100TX must use Category 5 or better cables; Gigabit Ethernet must use Category 5"e" cables.

- Check your uplink switch. When connecting to another hub or switch, set the switch to uplink on only one hub/switch and use a standard, straight-through network cable. This switch may be connected to another 10/100 Mbps switch or hub, but it will only run at 10 Mbps.

- Check your computer's software. Check your operating system manual for instructions on configuring your network for file and print sharing.

AsantéCare

Optional extended technical support and product warranty for additional years is available for a nominal fee. Contact Asanté for complete details.

Need more help?

Consult the Asanté website (www.asante.com) for additional troubleshooting tips and frequently asked questions (FAQ). You may also contact Asanté Technical Support during standard business hours (7am to 6pm MST, Monday-Friday).

Email: support@asante.com  
Phone: 801-566-8991  
FAX: 801-566-3787

Product Specifications

- Connector:** Gigabit Ethernet (1000BaseT, 100BaseTX, 10BaseT): RJ-45
- Drivers:** Apple Mac OS 9 and OS X  
Microsoft Windows 98, 98 Second Edition and Me  
Microsoft Windows NT and 2000 Professional  
Linux  
*See the Asanté website for the latest drivers*
- Status Indicators:** 1000 Mbps Link/Activity, 100 Mbps Link/Activity and 10 Mbps Link/Activity
- Bus Interface:** PCI v2.2 bus master, 32/64-bit, 33/66 MHz
- Dimensions:** 2.5 x 6.4 inches (63 x 163 mm)

Environmental Range

- Operating Temperature:** 32-104° F (0-40° C)
- Relative Humidity:** 10-95% (non-condensing)
- Power:** Maximum 7 W

Standards Compliance

- Network:** IEEE 802.3u Auto Negotiation and parallel detection  
IEEE 802.3ab Gigabit Ethernet over 4 pairs of UTP Category 5 (1000BaseT); Asanté Certified Gigabit Ethernet Cable or EIA/TIA-568A Category 5E recommended.  
IEEE 802.3u Fast Ethernet over 2 pairs of UTP Category 5 (100BaseTX).  
IEEE 802.3 Ethernet over 2 pairs of UTP Category 3 (10BaseT)
- Distance:** Recommended maximum distance is 328 feet (100 meters). Exclusive 10BaseT Extended Distance rated up to 613 feet (187 meters) over Category 5 cable or 492 feet (150 meters) over Category 3 cable.
- Full Duplex:** Support for 10/100/1000 Mbps data rates
- Virtual Network:** Virtual LAN (VLAN) tag support
- Regulatory:** FCC Class A, CE Mark

Safety and Regulatory Compliance

FCC Compliance Statement

This hardware device complies with Part 15 of the FCC Rules. Operation is subject to the following two conditions: 1) this device may not cause harmful interference, and 2) this device must accept any interference received, including interference that may cause undesired operation. NOTE: This equipment has been tested and found to comply with the limits for a Class A digital device, pursuant to Part 15 of the FCC Rules. These limits are designed to provide reasonable protection against harmful interference when the equipment is operated in a commercial environment. This equipment generates, uses, and can radiate radio frequency energy and, if not installed and used in accordance with the instruction manual, may cause harmful interference to radio communications. Operation of this equipment in a residential area is likely to cause harmful interference in which case the user will be required to correct the interference at his own expense. However, there is no guarantee that interference will not occur in a particular installation. If you suspect this equipment is causing interference, turn your unit on and off while your radio or TV is showing interference, if the interference disappears when you turn the unit off and reappears when you turn the unit on, something in the unit is causing interference. You can try to correct the interference by one or more of the following measures: 1) reorient or relocate the receiving antenna; 2) increase the separation between the equipment and the receiver; 3) connect the equipment to an outlet on a circuit different from that to which the receiver is connected; 4) consult the place of purchase or an experienced radio/television technician for additional suggestions. Any changes or modifications not expressly approved by the party responsible for compliance could void the user's authority to operate the equipment.

Safety Advisory

1. Always turn off power to your computer before installing hardware.
2. Always practice ESD techniques when installing hardware.
3. Always use this product in a cool, dry, dust-free environment or danger of electrocution or fire may result.
4. Never insert anything other than the recommended cable into the RJ45 port or damage may result.

Visit Asanté at  
[www.asante.com](http://www.asante.com)

Main Corporate Telephone Numbers  
800-662-9686 (Home/Office Solutions)  
800-303-9121 (Enterprise Solutions)  
408-435-8388

Technical Support  
801-566-8991 (Worldwide)

Technical Support Fax  
801-566-3787



Copyright © 2000 Asanté Technologies, Inc. Asanté, the Asanté logo and FriendlyNET are trademarks of Asanté Technologies. All other brand names and products are trademarks or registered trademarks of their respective holders. All features and specifications are subject to change without prior notice. 06-00589-00 Rev. A, 11/00